



**INVITATION FOR BIDS
No. IFB 26-030-ARM D**

**SEALED OFFERS FOR THE
MOLOKA'I IRRIGATION SYSTEM
MISCELLANEOUS ON-CALL SERVICES
ISLAND OF MOLOKA'I, HAWAII**

SHARON HURD, Chairperson
Department of Agriculture and Biosecurity

Name of Offeror

Company Name

Chief Engineer
Agricultural Resource Management Division
Department of Agriculture and Biosecurity
State of Hawai'i
Honolulu, Hawai'i

Dear Sir:

The undersigned has carefully read and understands the terms and conditions specified in the Offer Form and Special Provisions attached hereto, and in the Interim General Conditions, dated October 1994, by reference made a part hereof and available upon request; and hereby submits the following offer to perform the work specified herein, all in accordance with the true intent and meaning thereof. The undersigned further understands and agrees that by submitting this offer, 1) Is declaring his/her offer is not in violation of Chapter 84, Hawai'i Revised Statutes, concerning prohibited State contracts, and 2) he/she is certifying that the prices submitted were independently arrived at without collusion.

The undersigned represents: **(Check \checkmark one only)**

- A **Hawai'i business** incorporated or organized under the laws of the State of Hawai'i; **OR**
- A **Compliant Non-Hawai'i business** not incorporated or organized under the laws of the State of Hawai'i, but registered at the State of Hawai'i Department of Commerce and Consumer Affairs Business Registration Division to do business in the State of Hawai'i.

State of incorporation: _____

Offeror is:

- Sole Proprietor Partnership Corporation Joint Venture
- Other _____

Federal Tax I.D. No.: _____

Hawai'i General Excise Tax License I.D. No.: _____

Payment address (if other than street address below): _____

City, State, Zip Code: _____

Business address (street address): _____

City, State, Zip Code: _____

Respectfully submitted:

Date: _____

Telephone No.: _____

Fax No.: _____

E-mail Address: _____

(x) _____
Authorized (Original) Signature

Name and Title (Please Type or Print)

* _____
Exact Legal Name of Company(Offeror)

*If Offeror is a "dba" or a "division" of a corporation, furnish the exact legal name of the corporation under which the award will be executed.

PROPOSAL

Item No.	Quantity	Unit	Description	Unit Price	Total
<u>BASE BID</u>					
METER & LATERAL INSTALLATION					
1.	2	EA	Option 1 Lateral Installation, inclusive of connection to main lateral, 2-1/2 inch copper lateral, meter box, metal frame, box & cover, pipe cushion, pavement restoration (complete in place).	\$ _____	\$ _____
2.	2	EA	Option 2 Lateral Installation, inclusive of connection to main lateral, 2-1/2 inch copper lateral, meter box, metal frame, box & cover, pipe cushion, pavement restoration (complete in place).	\$ _____	\$ _____
3.	4	EA	2-inch Water Meter, Badger Recordall Model 170 Disc Series or approved equal. (complete in place)	\$ _____	\$ _____
4.	5	EA	Cut & Remove 2' Diameter Albizia Tree	\$ _____	\$ _____
5.	2	EA	Cut & Remove 3'-4' Diameter Albizia Tree	\$ _____	\$ _____
6.	2	EA	Cut & Remove 5'-6' Diameter Albizia Tree	\$ _____	\$ _____
7.	1	ALLOW.	Emergency "On-Call" Services	\$ 75,000.00	\$ 75,000.00
Total Base Bid (Items 1-7)					\$ _____

APPRENTICESHIP AGREEMENT PREFERENCE

1. If applicable to this project, any bidder seeking the preference must be a party to an apprenticeship agreement registered with the State Department of Labor and Industrial Relations (DLIR) at the time the bid is submitted for each apprenticeable trade the bidder will employ to construct the project. “Employ” means the employment of a person in an employer-employee relationship.
 - a. The apprenticeship agreement shall be registered with the DLIR and conform to the requirements of Hawai'i Revised Statutes Chapter 372.
 - b. Subcontractors do not have to be a party to an apprenticeship agreement for the bidder to obtain preference.
 - c. The bidder is not required to have apprentices in its employ at the time the bid is submitted to qualify for the preference.
2. A bidder seeking the preference must state the apprenticeable trade the bidder will employ for each trade to be employed to perform the work by submitting a completed signed original Certification Form 1 verifying participation in an apprenticeship program registered with DLIR. “Apprenticeable trade” shall have the same meaning as “apprenticeable occupation” pursuant to Hawai'i Administrative Rules (HAR) §12-30-5.
 - a. The *Certification Form 1* shall be authorized by an apprenticeship sponsor listed on the DLIR list of registered apprenticeship programs. “Sponsor” means an operator of an apprenticeship program and in whose name the program is approved and registered with the DLIR pursuant to HAR §12-30-1.
 - b. The authorization shall be an original signature by an authorized official of the apprenticeship sponsor.
 - c. The completed signed original Certification Form 1 for each trade must be submitted with the bid. Previous certifications shall not apply.
 - d. When filling out the *Certification Form 1*, the name of Apprenticeable Trade and Apprenticeship Sponsor must be the same as recorded in the List of Construction Trades in Registered Apprenticeship Programs that is posted on the DLIR website. “Registered apprenticeship program” means a construction trade program approved by the DLIR pursuant to HAR §12-30-1 and §12-30-4.
 - e. The *Certificate Form 1* and the List of Construction Trades in Registered Apprenticeship Programs is available on the DLIR website at:
<https://labor.hawaii.gov/wdd/>.
3. Upon receiving the *Certification Form 1*, the Procurement Officer will verify that the apprenticeship program is on the List of Construction Trades in Registered Apprenticeship Programs and that the form is signed by an authorized official of the Apprenticeship

Program Sponsor. If the programs and signature are not confirmed by the DLIR, the bidder will not qualify for the preference.

4. If the bidder is certified to participate in an apprenticeship program for each trade which will be employed by the bidder for the project, a preference will be applied to decrease the bidder's bid amount by five percent (5%) for evaluation purposes.
5. Should the bidder qualify for other preferences (e.g. Hawai'i Products), all applicable preferences shall be applied to the bid price.

CONTRIBUTIONS BY STATE AND COUNTY CONTRACTORS PROHIBITED

Contractors are hereby notified of the applicability of Section 11-355, HRS, which states that campaign contributions are prohibited from specified State or county government contractors during the term of the contract if the contractors are paid with funds appropriated by a legislative body.

CONDITION OF AWARD

It is understood that the award of the contract will be made on the basis of the lowest responsible Total Base Bid (Items 1 to 7) selected by the Board of Agriculture and Biosecurity.

In the event the low bid is below the available funds certified by the appropriate fiscal officer, the head of the purchasing agency responsible for the procurement in question is authorized to award Additives to the lowest bidder. The award of Additives may be in any order or combination such that the Base Bid plus Additives do not exceed the available funds.

It is understood and agreed that the Board of Agriculture and Biosecurity reserves the right to reject any and/or all bids and waive any defects when, in the Board's opinion, such rejection or waiver will be for the best interest of the State of Hawai'i.

In the event all bids exceed available funds certified by the appropriate fiscal officer, the head of the purchasing agency responsible for the procurement in question is authorized in situations where time or economic considerations preclude re-solicitation of work of a reduced scope to negotiate an adjustment of the bid price, including changes in the bid requirements, with the low responsible and responsive bidder, in order to bring the bid within the amount of available funds. It is understood and agreed upon that the head of the purchasing agency may delete a portion or all of any item(s) in the proposal at the stated unit or lump sum price as necessary to stay within the available funding. The bidder is responsible to make an earnest effort to represent the actual cost of each item, including all materials, labor, equipment, overhead and profit in their bid proposal to preclude claims of anticipated profit or loss of profit because of an unbalanced bid proposal.

It is also understood that if a mutually agreeable cost for the reduced scope of work necessitated by a lack of available funds cannot be agreed upon between the bidder and the head of the purchasing agency within 14 calendar days after the bid opening, then the bid may be rejected in the best interest of the purchasing agency, and the head of the purchasing agency may negotiate in progressive order (lowest to highest) with the next lowest responsible and responsive bidder.

It is also understood and agreed that the award of the contract shall be conditioned upon funds being made available for this project and further upon the right of the Board of Agriculture and Biosecurity to hold all bids received for a period of sixty (60) days from the date of the opening thereof, unless otherwise required by law, during which time no bid may be withdrawn.

It is also understood that Notice to Proceed may be delayed up to one (1) year after the bid opening date, and that no additional compensation will be provided for any claim for escalation or delay for issuance of Notice to Proceed on or before that date.

It is also understood and agreed that the quantities given herewith are approximate only and are subject to increase or decrease, and that the undersigned will perform all quantities of work as either increased or decreased, in accordance with the provisions of the Contract Specifications.

It is also understood and agreed that the estimated quantities shown for the items for which a UNIT PRICE is asked in this Proposal are only for the purpose of comparing on a uniform basis, bids offered for the work under this contract, and the undersigned agrees that he is satisfied with and will at no time, dispute said estimated quantities as a means of claims for anticipated profit or loss of profit, because of a difference between the quantities of the various classes of work done or the materials and equipment installed, and the said estimated quantities. On UNIT PRICE bids, payment will be made only for the actual number of units incorporated into the finished project at the contract UNIT PRICE.

After the proposals are opened and read, the figures will be extended and/or totaled in accordance with the bid prices of the acceptable proposals and the totals will be compared. In the comparison of bids, words written in the proposal shall govern over figures and unit prices will govern over totals. Until the award of the contract, however, the right will be reserved to reject any and all proposals and to waive any defects or technicalities as may be deemed best for the interest of the State.

It is also understood and agreed that liquidated damages in the amount of ONE HUNDRED FIFTY AND NO/100 DOLLARS (\$150.00) for each and every calendar day in excess thereof prior to completion of the contract shall be withheld from payments due to the Contractor.

It is also understood and agreed that if this bid is accepted, the successful bidder must enter into and execute a contract with the Board of Agriculture and Biosecurity and furnish a Performance and Payment Bond, as required by law. These bonds shall conform to provisions of Section 103D-324 and 325, Hawai'i Revised Statutes and any law applicable hereto.

It is also understood and agreed that the successful bidder will provide all necessary labor, materials, tools, equipment, and other incidentals necessary to do all the work and furnish all the materials specified in the contract in the manner and time herein prescribed, and according to the requirements of the Engineer as therein set forth.

It is understood that by submitting this proposal, the undersigned is declaring that his firm has not been assisted or represented on this matter by an individual who has, in a State capacity, been involved in the subject matter of this contract in the past two years.

It is understood that by submitting this proposal in accordance with HAR 3-122-192, the undersigned is declaring that the price submitted is independently arrived without collusion.

It is also understood that by submitting this proposal, a Certification for Safety and Health Programs for bids in excess of \$100,000 (in accordance with HRS 396-18), the undersigned certifies that his organization will have a written safety and health plan for this project that will be available and implemented by the Notice to Proceed date of this project. Details of the requirements of this plan may be obtained from the Department of Labor and Industrial Relations, Occupational, Safety and Health Division (HIOSH).

It is further understood and agreed that the successful bidder shall comply with paragraph 3.1.a "SUBCONTRACTING" of the General Provisions which requires that the contractor shall perform with his own organization and with the assistance of workmen under his immediate superintendence, work of a value not less than twenty percent (20%) of the value of all work embraced in the Contract, except that certain contract items of work, if specifically referred to in the special provisions, will be exempted from said twenty percent requirement.

Compliance with §103-310 HRS. As a condition of award all bidders shall comply with all laws governing entities doing business in the State, including Chapter 237 HRS (general excise tax); Chapter 383 HRS (employment security – unemployment insurance); Chapter 386 HRS (workers compensation); Chapter 392 HRS (temporary disability insurance); and Chapter 393 HRS (pre-paid health care), and shall produce all documents to the State (DLNR, Engineering Division) required to demonstrate compliance with these subsections. Any bidder making a false affirmation or certification under this subsection shall be suspended and may be debarred from further offerings or awards pursuant to §103D-702 HRS.

RECEIPT OF ADDENDA

The bidder also acknowledges receipt of any and all addenda issued by the Agricultural Resource Management Division, by recording the date of receipt of the respective addenda in the space provided below:

<u>Addendum</u>	<u>Date Received</u>	<u>Addendum</u>	<u>Date Received</u>
No.1	_____	No. 5	_____
No.2	_____	No. 6	_____
No.3	_____	No. 7	_____
No.4	_____	No. 8	_____

JOINT CONTRACTORS OR SUBCONTRACTORS TO BE ENGAGED ON THIS PROJECT

The Bidder agrees that the following is a complete listing of all joint contractors or subcontractors covered under Chapter 444, Hawai'i Revised Statutes (HRS), who will be engaged by the Bidder on this project to perform the required work indicated pursuant to Section 103D-302, HRS. It is the sole responsibility of the contractor to review the requirements of this Project and determine the appropriate licenses that are required to complete the Project. The Bidder certifies that the completed listing of joint contractors or subcontractors fulfills the requirements for the project and the Bidder, together with the listed subcontractors or joint contractors have all the specialty contractor's licenses to complete the work, except as provided for in HRS §103D-302(b). Failure of the Bidder to comply with this requirement may be just cause for rejection of the bid.

“A” General Engineering Contractors and “B” General Building Contractors are reminded that due to the Hawai'i Supreme Court's January 28, 2002 decision in Okada Trucking Co., Ltd. v. Board of Water Supply, et al., 97 Haw. 450 (2002), they are prohibited from undertaking any work, solely or as part of a larger project, which would require the general contractor to act as a specialty contractor in any area in which the general contractor has no license. Although the “A” and “B” contractor may still bid on and act as the “prime” contractor on an “A” or “B” project (See, HRS §444-7 for the definitions of an “A” and “B” project.), respectively, the “A” and “B” contractor may only perform work in the areas in which they have the appropriate contractor's license (*An “A” or “B” contractor obtains “C” specialty contractor's licenses either on its own, or automatically under HAR § 16-77-32*). The remaining work must be performed by appropriately licensed entities.

General Engineering “A” Contractors automatically have these “C” specialty contractor's licenses: C-3, C-9, C-10, C-17, C-24, C-31a, C-32, C-35, C-37a, C-37b, C-38, C-43, C-49, C-56, C-57a, C-57b and C-61.

General Building “B” Contractors automatically have these “C” specialty contractor's licenses: C-5, C-6, C-10, C-12, C-24, C-25, C-31a, C-32a, C-42a and C-42b.

In completing the Joint Contractors or Subcontractors List, describe the specialty contractor's nature and scope of work to be performed for this project and provide the complete firm name of the joint contractor or subcontractor in the respective columns. If the Bidder is a general contractor and providing the work of the required specialty contractor, fill in the Bidder's (general contractor's) name and nature and scope of work to be performed on this project.

List only one joint contractor or subcontractor per required specialty contractor's classification, unless within the same specialty, the work of each joint contractor or subcontractor can be described so that there is no overlap in work descriptions.

If a contractor's license is required by law for the performance of the work which is called for in this bid, the bidder and all subcontractors must have the required license before the submission of the bidder's proposal in the case of a non-federal aid project, and for federal-aid projects, the bidder must have the required license prior to the award of the project and all subcontractors prior to the start of the subcontracted work.

COMPLETE FIRM NAME OF JOINT CONTRACTOR OR SUBCONTRACTOR	NATURE AND SCOPE OF WORK TO BE PERFORMED

Enclosed herewith is a:

- 1. Surety Bond (*1))
- 2. Certificate of Deposit (*2))
- 3. Cashier's Check (*2))
- 4. Certified Check (*2)) in the
- 5. Official Check (*2)) amount
- 6. Share Certificate (*2)) of
- 7. Teller's Check (*2))
- 8. Treasurer's Check (*2))

(Cross Out Those Not Applicable)

_____ Dollars (\$ _____)

as required by law.

Respectfully submitted,

Name of Company, Joint Venture
or Partnership

Contractor's License No.

By _____

Signature (*4)

Title _____

Print Name _____

Date _____

Address _____

Telephone No. _____

E-Mail Address _____

NOTES:

1. Surety bond underwritten by a company licensed to issue bonds in this State;
2. A certificate of deposit; share certificate; or cashier's, treasurer's, teller's, or official check drawn by, or a certified check accepted by, and payable on demand to the State by a bank, a savings institution, or credit union insured by the Federal Deposit Insurance Corporation or the National Credit Union Administration.
 - A. These instruments may be utilized only to a maximum of \$100,000.
 - B. If the required security or bond amount totals over \$100,000, more than one instrument not exceeding \$100,000 each and issued by different financial institutions shall be accepted.
3. Please attach to this page evidence of the authority of this officer to submit bids on behalf of the Company and also the names and residence addresses of all officers of the Company.
4. Fill in all blank spaces with information asked for or bid may be invalidated.
PROPOSAL MUST BE INTACT, MISSING PAGES MAY INVALIDATE YOUR BID.

Certification Regarding Debarment, Suspension, and Other Responsibility Matters

The prospective participant certifies to the best of its knowledge and belief that it and the principals:

- (a) Are not presently debarred, suspended, proposed for debarment, declared ineligible, or voluntarily excluded from covered transactions by any Federal department or agency;
- (b) Have not within a three year period preceding this proposal been convicted of or had a civil judgment rendered against them for commission of fraud or a criminal offense in connection with obtaining, attempting to obtain, or performing a public (Federal, State, or local) transaction or contract under a public transaction: violation of Federal or State antitrust statutes or commission of embezzlement, theft, forgery, bribery, falsification or destruction of records, making false statements, or receiving stolen property;
- (c) Are not presently indicted for otherwise criminally or civilly charged by a government entity (Federal, State, or local) with commission of any of the offenses enumerated in paragraph (1) (b) of this certification; and
- (d) Have not within a three-year period preceding this application/proposal had one or more public transactions (Federal, State, or local) terminated or cause or default.

I understand that a false statement on this certification may be ground for rejection of this proposal or termination of the award. In addition, under 18 U SC Sec. 1001, a false statement may result in a fine of up to \$10,000 or imprisonment for up to 5 years, or both.

Typed Name of Business

Typed Name & Title of Authorized Representative

Signature of Authorized Representative

Date

I am unable to certify to the above statements. My explanation is attached.

SPECIAL PROVISIONS

TERMS AND ACRONYMS USED HEREIN

Chief Engineer	=	The Chief Engineer of Department of Agriculture and Biosecurity (DAB), Agricultural Resource Management Division.
State	=	State of Hawai'i.
Department	=	Department of Agriculture and Biosecurity (DAB). Located at 1428 South King Street, Building B, Honolulu, Hawai'i 96814;
SPO	=	State Procurement Office of the State of Hawai'i, located at 1151 Punchbowl Street, Room, 416, Honolulu, Hawai'i 96813; P. O. Box 119, Honolulu, Hawai'i 96810-0119.
Bidder or Offeror	=	Any individual, partnership, firm, corporation, joint venture, or other legal entity submitting directly or through a duly authorized representative or agent, a bid for the good, service, or construction contemplated.
Contractor	=	Any individual, partnership, firm, corporation, joint venture, or other legal entity undertaking the execution of the work under the terms of the contract with the State of Hawai'i, and acting directly or through his, their or its agents, or employees.
HRS	=	Hawai'i Revised Statutes
HAR	=	Hawai'i Administrative Rules
GC	=	Hawai'i Department of the Attorney General Conditions (Form AG-008)
IFB	=	Invitation for Bids
RFP	=	Request for Proposals
GET	=	General Excise Tax

SCOPE

This IFB consists of "On-Call" services for the Moloka'i Irrigation System. Work may include, but not limited to the following:

1. Installation of irrigation water service laterals, meters, and meter boxes.
2. Removal of trees from reservoir embankments, access roads, and various DAB parcels.
3. Removal of sediment and debris from tunnels, ditches, flumes, culverts, etc.
4. Repair/replacement of gate valves varying in size from 4" to 12".
5. Locating and repairing/replacing segments of leaking irrigation pipelines.
6. Installation/repair/replacement of chain link fencing.
7. Trouble shooting, repair, and/or replacement of pumps and ancillary pump components in Waikolu Valley.
8. Hauling/disposal of miscellaneous illegally dumped materials.

Work shall be in accordance with these Special Provisions, the Offer Form, the Interim General Conditions, and the GC, included by reference and are available on the SPO website: <https://spo.hawaii.gov/ag-008-103d-general-conditions-1-10-23-2/>.

CONTRACT ADMINISTRATOR

For purposes of this contract Mr. Glenn Okamoto of DAB Agricultural Resource Management Division, is the designated Contract Administrator. He may be contacted by phone at (808) 973-9436, or by e-mail at glenn.m.okamoto@hawaii.gov.

TERM OF CONTRACT

The term of the contract is 730 calendar days from the Notice To Proceed date issued by DAB. DAB intends to execute a contract following the bid opening, and confirmation of the lowest responsible bidder.

BID PREPARATION

Offer Form Offeror is requested to submit the completed Offer Form using Offeror's exact legal name as registered with the Department of Commerce and Consumer Affairs, if applicable; and to indicate exact legal name in the appropriate space on Offer Form, page OF-3. Failure to do so may delay proper execution of the contract.

The authorized signature on page OF-3 of the Offer Form shall be an original signature. If unsigned the offer shall be automatically rejected unless accompanied by other material, containing an original signature, indicating the Offeror's intent to be bound.

Hourly Billing Rates Offeror shall provide hourly billing rates and corresponding North American Industry Classification System (NAICS) classification codes for personnel anticipated to perform work under this solicitation. The billing rates shall be attached to the Offer Form. Failure to provide the billing rates will result in automatic rejection of the offer.

Bid Quotation. Unit bid price shall include all costs, including all applicable taxes, as required by this IFB.

Each line item shall be priced separately, and the unit prices extended and totaled. In case of error in extensions or price, unit price will govern. In case of error in Estimated Total Sum Bid, the sum of the total amount bid for each appropriate line item shall govern.

Offeror must bid on all line items to be considered for award as award shall be made to one successful offeror.

Intention to Bid. Notice of intention to bid is not required for this project.

License. Due to the nature of work contemplated, bidders must possess a valid State Contractor's license, Classification A.

Tax Liability. Work to be performed under this solicitation is a business activity taxable under Chapter 237, HRS, and vendors are advised that they are liable for the Hawai'i GET at the current rate, and adjusted if the tax rate changes. If, however, an Offeror is a person exempt by the HRS

from paying the GET and therefore not liable for the taxes on this solicitation, Offeror shall state its tax exempt status and cite the HRS chapter or section allowing the exemption.

Taxpayer Preference. For evaluation purposes, pursuant to §103D-1008, HRS, the Bidder's tax-exempt price offer submitted in response to an IFB shall be increased by the applicable retail rate of general excise tax and the applicable use tax. Under no circumstance shall the dollar amount of the award include the aforementioned adjustment.

Tax Clearance. Pursuant to § 103D-328, HRS, Successful Offeror shall be required to submit a Vendor Compliance Certificate as proof of current tax liabilities, see <http://vendors.ehawaii.gov> . The Contractor is also required to submit a Vendor Compliance certificate for final payment on the contract.

METHOD OF AWARD

Award, if any, will be made to the responsive, responsible Offeror submitting the lowest Total Base Bid (Items 1-7).

Act 52, SLH 2003, amended §103D-310, HRS, by adding subsection (c) which, in part, follows:

"(c) All offerors, upon award of contract, shall comply with all laws governing entities doing business in the State, including chapters 237, 383, 386, 392, and 393, and shall:

- (1) Be incorporated or organized under the laws of the State; or
- (2) Be registered to do business in the State as a separate branch or division that is capable of fully performing under the contract."

At the release of this solicitation, implementation of the law is pending guidance from the Departments of Labor and Industrial Relations and Commerce and Consumer Affairs. Should guidance be received and implemented prior to award of this contract, the prospective awardee will be required to comply.

EXECUTION OF CONTRACT

Successful bidder(s) shall be required to provide a Labor and Material Payment Bond.

QUANTITY

The State reserves the right to purchase larger or smaller quantities at the price quoted on this bid. The State shall not have set minimum quantity to be purchased in this contract.

INVOICING AND PAYMENTS

Each invoice must specify the following:

1. Name of person issuing each invoice.
2. Title of project and purchase order number.
3. Itemized break-down of materials and delivered.
4. Copy of signed delivery slips.

Original and three copies of the invoices shall be sent to:

Agricultural Resource Management Division
1428 S. King St.
Honolulu, Hawai'i 96814

Sections 103-10, HRS provides that the State shall have thirty (30) calendar days after receipt of invoice or satisfactory delivery of goods or performance of the services to make payment. For this reason, the State will reject any bid submitted with a condition requiring payment within a shorter period. Further, the State will reject any bid submitted with a condition requiring interest payments greater than that allowed by Section 103-10 HRS, as amended.

The State will not recognize any requirement established by the Contractor and communicated to the State after award of the contract, which requires payment within a shorter period or interest payment not in conformance with statute.

DELIVERY EXTENSION

Contractor shall complete the work within the time specified in the Special Provisions. If the Contractor fails to complete the work within the time specified, liquidated damages in accordance with the LIQUIDATED DAMAGES provision below shall apply. However, Contractor shall not be held responsible for the delay provided he notifies the Department in accordance with GC Section 13 TERMINATION FOR DEFAULT, subsection (d) Excuse for nonperformance or delayed performance, and the reason for the delay is one of the allowable causes for delay as provided for in Section 13 (d).

GC Section 13 (d) is amended to include delay due to reason(s) beyond the control of the Contractor as a cause for delay for which the Contractor shall not be deemed to be in default. The Chief Engineer shall be the sole judge of whether such delay is truly beyond the control of the Contractor and whether the extension will be granted. No such extension, however, shall be deemed a waiver of the right of the State to terminate the contract or to assess liquidated damages for delays not covered by specific authorized extension.

ADDENDA AND INTERPRETATIONS

Discrepancies, omissions, or doubts as to the meaning of Offer Form and Special Provisions should be communicated via HlePRO no later than seven (7) days prior to the date fixed for bid opening.

Any interpretation, if made and any supplemental instruction will be provided via HlePRO. Failure of any bidder to receive any such addendum or interpretations shall not relieve such bidder from an obligation under his bid submitted. All addenda so issued shall become part of the contract documents.

RIGHTS AND REMEDIES

In the event the Contractor fails, refuses or neglects to perform the service in accordance with the requirements of either the Special Provisions, the Offer Form, or GC, in addition to the recourse stated in the GC, the State reserves the right to purchase in the open market a corresponding quantity of the services specified herein and to deduct from any money due or that may thereafter become due the Contractor the difference between the prices named in the contract and the actual cost thereof to the State. In any case any money due Contractor is

insufficient for said purpose, the Contractor shall pay the difference upon demand by the State. The State may also utilize all other remedies provided by law.

LIQUIDATED DAMAGES

Refer to Section 9 of the GC, Liquidated damages is fixed at the sum of ONE HUNDRED FIFTY DOLLARS (\$150.00) for each and every calendar day the Contractor delays in the completion of any item of his contract after the required date of said completion. Liquidated damages may be deducted from any payments due or to become due to the Contractor.

PROTEST

A protest shall be submitted in writing within five (5) working days after the aggrieved person knows or should have known of the facts giving rise thereto; provided that a protest based upon the content of the solicitation shall be submitted in writing prior to the date set for receipt of offers. Further provided that a protest of an award or proposed award shall be submitted within five (5) working days after the posting of award of the contract.

The notice of award letter, if any, resulting from this solicitation shall be posted on SPO

Any protest pursuant to §103D-701, HRS, and Section 3-126-3, HAR, shall be submitted in writing to the Agricultural Resource Management Division, Chief Engineer, 1428 S. King Street, Honolulu, Hawai'i 96814.

ADDITIONS, AMENDMENTS AND CLARIFICATIONS TO THE GC

Approvals. Any agreement arising out of this offer may be subject to the approval of the Department of Attorney General as to form, and is subject to all further approvals, including the approval of the Governor, required by statute, regulation, rule, order, or other directive.

Cancellation of Solicitations and Rejection of Offers. The solicitation may be cancelled or the offers may be rejected, in whole or in part, when in the best interest of the purchasing agency, as provided in §3122-95 through 3-122-97, HAR.

Confidentiality of Material. All material given to or made available to the Contractor by virtue of this contract, which is identified as proprietary or confidential information, will be safe guarded by the Contractor and shall not be disclosed to any individual or organization without the prior written approval of the STATE.

All information, data, or other material provided by the Offeror or the Contractor to the State shall be subject to the Uniform Information Practices Act, chapter 92F, HRS. The Offeror shall designate in writing to the Chief Engineer those portions of its unpriced offer or any subsequent submittal that are trade secrets or other proprietary data that the Offeror desires to remain confidential, subject to §3-122-58, HAR, in the case of an RFP, or §3-122-30, HAR, in the case of an IFB. The Offeror shall state in its written communication to the Chief Engineer, the reason(s) for designating the material as confidential, for example, trade secrets. The Offeror shall submit the material designated as confidential in such manner that the material is readily separable from the offer in order to facilitate inspection of the non-confidential portion of the offer.

Price is not confidential and will not be withheld. In addition, in the case of an IFB, makes and models, Catalogue numbers of items offered, deliveries, and terms of payment shall be publicly available at the time of opening regardless of any designation to the contrary.

If a request is made to inspect the confidential material, the inspection shall be subject to written determination by the Office of the Attorney General in accordance with chapter 92F, HRS. If it is determined that the material designated as confidential is subject to disclosure, the material shall be open to public inspection, unless the Offeror protests under chapter 3-126, HAR. If the request to inspect the confidential material is denied, the decision may be appealed to the Office of Information Practices in accordance with §92F-15.5, HRS.

Nondiscrimination. No person performing work under this Agreement, including any subcontractor, employee, or agency of the Contractor, shall engage in any discrimination that is prohibited by any applicable federal, state, or county law.

Records Retention. The Contractor and any subcontractors shall maintain the books and records that relate to the Agreement and any cost or pricing data for three (3) years from the date of final payment under this Agreement.

Correctional Industries. Goods and services available through Correctional Industries (CI) programs may be the same or similar to those awarded by competitive sealed bids or proposals. Agencies participating in SPO requirements (price list) contracts may also procure directly from CI and shall not be considered in violation of the terms and conditions of any SPO contract.

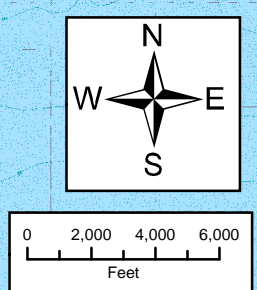
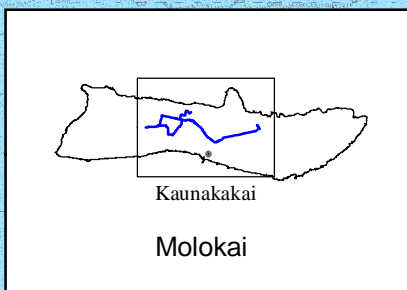

Legend	
	Ditch
	Tunnel
	Pipe
	Flume
	Booster Pump
	Well
	Reservoir
	Gov't Land
	Annual Rainfall

Hawaii State Department of Agriculture

Molokai Irrigation System

Island of Molokai

NOTES:

1. INSTALL NEW 2" BADGER RECORDALL MODEL 170 DISC SERIES METER OR APPROVED EQUAL FOR VARIOUS PARCELS OF LAND WITHIN THE MOLOKAI IRRIGATION SYSTEM.
2. NEW 2-1/2" LATERAL SHALL BE INSTALLED IN ACCORDANCE WITH BOARD OF WATER SUPPLY (BWS) STANDARD DETAIL L37 AND L38.
3. NEW 2" METER AND METER MANHOLE SHALL BE INSTALLED IN ACCORDANCE WITH BWS STANDARD DETAILS M12.
4. EXISTING AC PAVEMENT SHALL BE SAWCUT AND RESTORED IN ACCORDANCE WITH STANDARD SPECIFICATIONS FOR PUBLIC WORKS CONSTRUCTION.
5. THE CONTRACTOR SHALL OBTAIN ALL NECESSARY PERMITS AND/OR APPROVALS PRIOR TO START OF WORK.
6. THE CONTRACTOR SHALL BE RESPONSIBLE FOR ANY TRAFFIC CONTROL NECESSARY TO COMPLETE WORK.
7. THE CONTRACTOR SHALL NOTIFY THE ENGINEER A MINIMUM OF SEVEN (7) CALENDAR DAYS PRIOR TO SHUTDOWN OF WATER.
8. SHUTDOWN OF WATER SHALL NOT EXCEED 24 HOURS WITHOUT APPROVAL FROM THE ENGINEER.

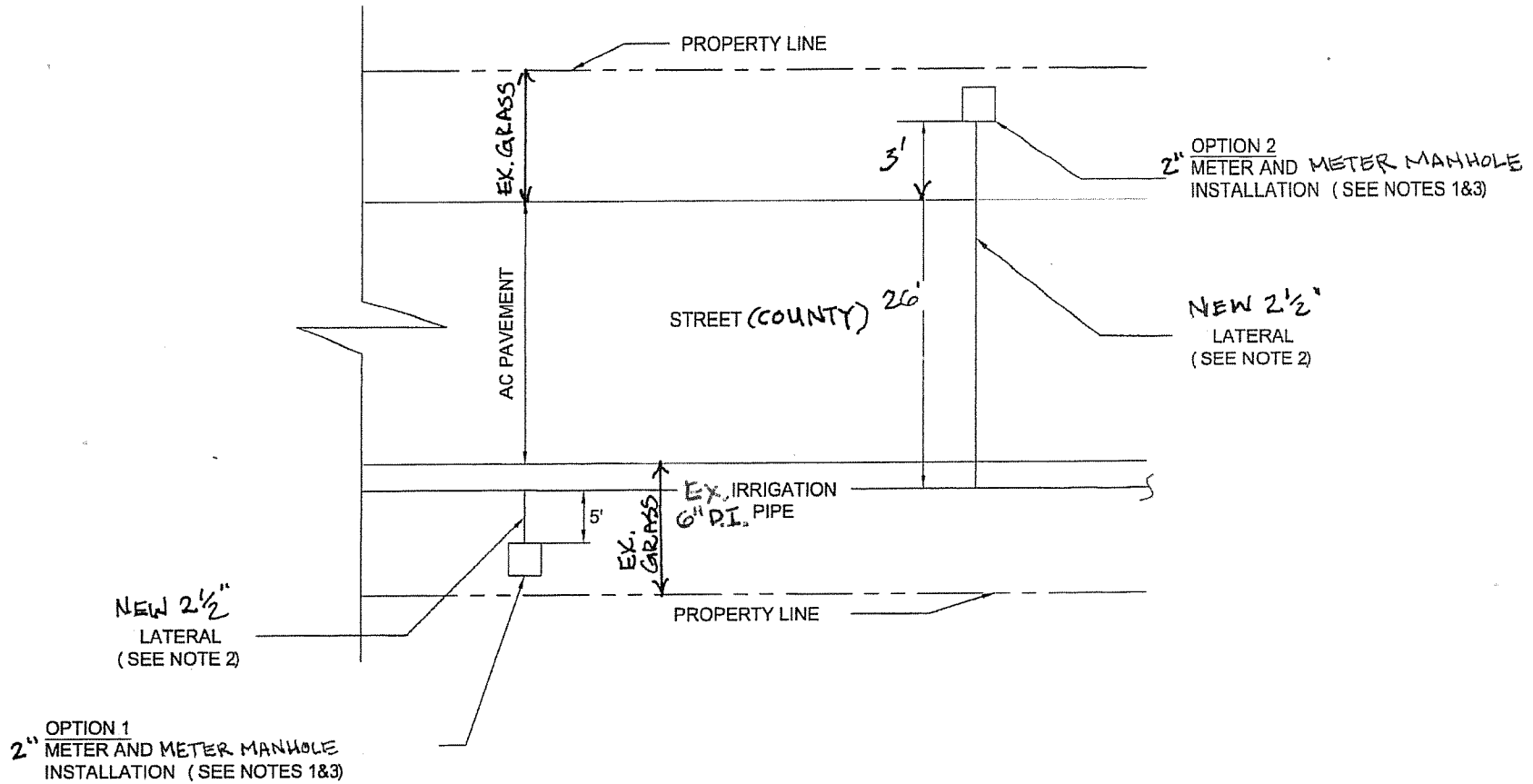

TYPICAL DETAIL CONDITION

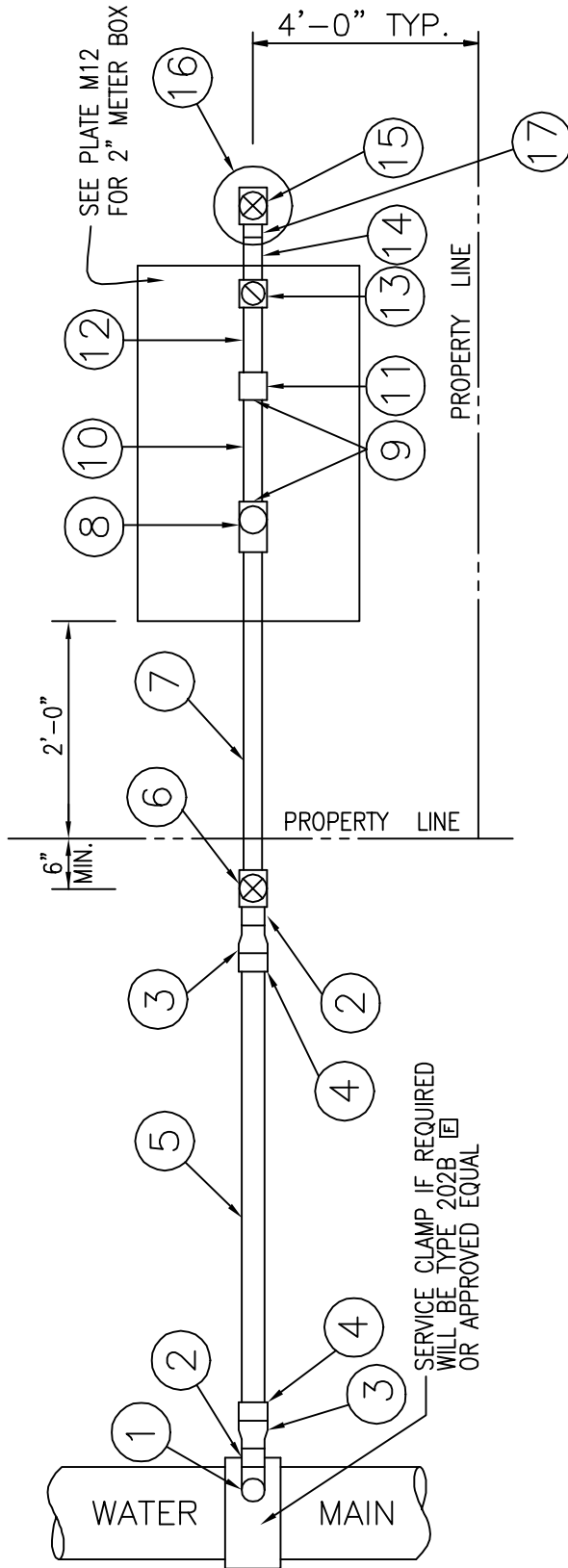

NOTE: SEE L38 FOR MATERIALS AND NOTES

2002
REVISION

MAUI

SINGLE SERVICE LATERAL
 (TYPE "D", 2" METER)
 SCALE: NTS

STANDARD
 DETAILS

L37

MAUI	SINGLE SERVICE LATERAL (TYPE "D", 2" METER) SCALE: NTS		STANDARD DETAILS	L38 REVISION 2002		
TYPE	METER SIZE	① *	② *	③ *	④ *	⑤ *
		STOP CORP.	BRASS NIPPLE	BRASS REDUCING COUPLING	COPPER ADAPTER	COPPER SERVICE TUBING
D	2"	2" AWWA THREAD x FEMALE I.P.T. FB 1600-7 F	2" x 4"	2 1/2" x 2" C 11-87 F	2 1/2" * (OR 2") MALE I.P.T. x COPPER	2 1/2" * (OR 2")
⑥	⑦	⑧	⑨	⑩	⑪	
BRONZE BALL VALVE	BRASS NIPPLE	VALVE METER	STAINLESS STL. BOLTS/NUTS	METER IDLER	METER COUPLING	
2" FEMALE I.P.T. B 11-777 F	2" x 48" (OR LENGTH TO FIT) F	2" FEMALE I.P.T. x FLANGE BF 13-777 F	5/8" x 3" TYPE 304	2" x 17" FLG. x FLG. ONE END PLUGED	2" FLG. x LOK PAK F	
⑫	⑬	⑭	⑮	⑯	⑰	
BRASS NIPPLE	BRASS CHECK VALVE	BRASS NIPPLE	BRONZE BALL VALVE	PLASTIC VALVE BOX	DIELECTRIC COUPLING	
2" x 6" F	2" IN-LINE SPRING HS 11-777 F	2" x 14" F	2" FEMALE I.P.T. B 11-777 HB-67 S F	10" AMETEK 10-181-014 W/ GREEN COVER 10-181-015	2" BRASS WITH ADAPTER AND CLOSE NIPPLE	

NOTES:

1. ALL FITTINGS AND MATERIALS LISTED BY BRAND NAMES OR APPROVED EQUAL.
2. SEE PLATE M23 FOR TRANSDUCER BRACKET INSTALLATION.
- * IF LENGTH OF SERVICE LATERAL IS LESS THAN 15 FEET, DELETE ITEMS ② AND ③ AND USE 2" SIZE FOR ITEMS ④ AND ⑤. SEE L37 FOR PLAN VIEW

F DENOTES FORD METER BOX MANUFACTURING CO. NUMBER.

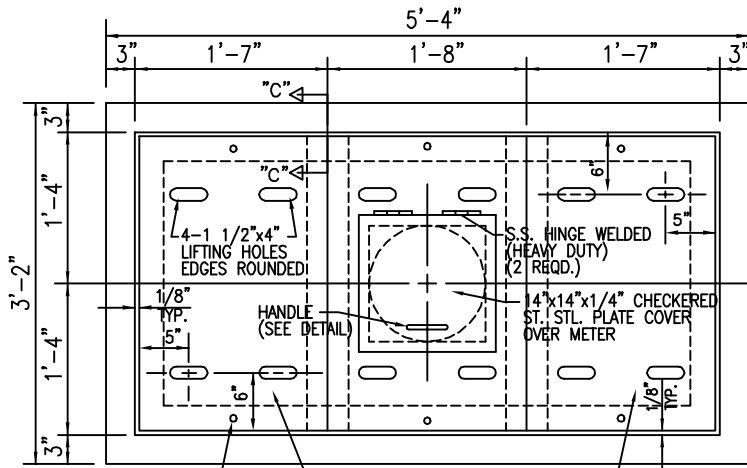
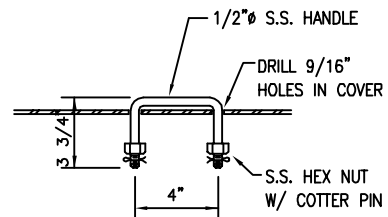

PLATE HOLD-DOWN ANCHOR
2 EACH PLATE COVER.
1/2" S.S. BOLT W/ PENTA
HEAD INTO EMBEDDED INSERT.
(SEE PLATE M11)

PLAN OF STAINLESS (316)
STEEL* MANHOLE COVER



HANDLE DETAIL

NOTE:

EACH PANEL WIDTH OF METER BOX
COVER MAY VARY SLIGHTLY ACCORDING
TO METER LOCATION.

COAT TOP OF
CHANNEL IRON
(SEE NOTE 1.)

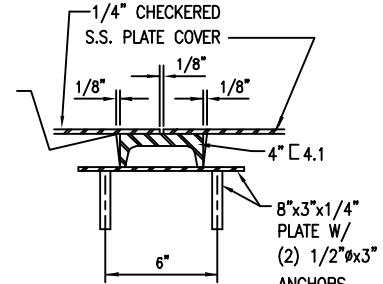

DETAIL "B"

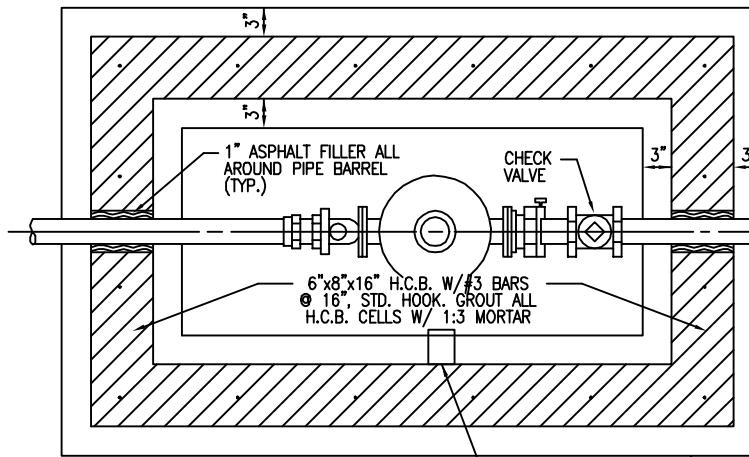

PLAN OF MANHOLE

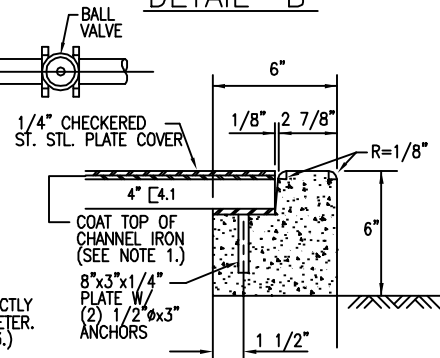

SECTION "C-C"

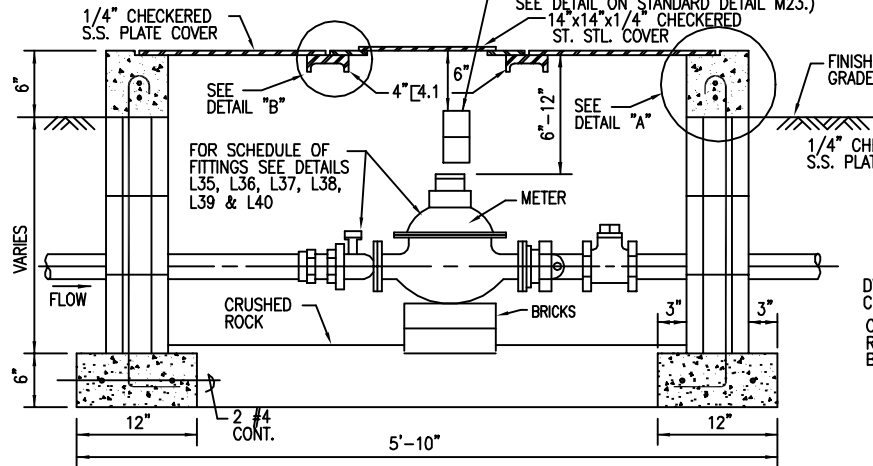

SECTION

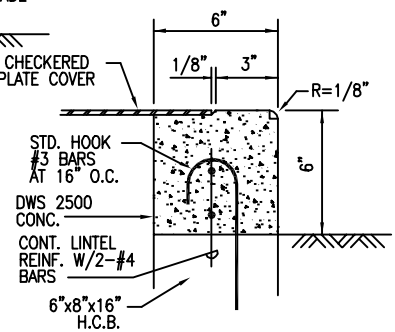

DETAIL "A"

NOTES:

1. COAT CONTACT POINT OF DISSIMILAR METALS W/ CHEVRON INDUSTRIAL MEMBRANE (ELASTOMERIC MEMBRANE) OR EQUAL.
2. ALL MILD STEEL SHALL BE HOT-DIPPED GALVANIZED.

* ALTERNATE = PROVIDE DESIGN WITH ANODIZED ALUMINUM COVER.

2002
REVISION

MAUI	1 1/2" & 2" METER MANHOLE STANDARD NON-TRAFFIC SCALE: NTS	STANDARD DETAILS	M12
------	---	---------------------	-----